

625-HCF-1641 Adjustable linkage CRF150R

Installation instructions:

Remove OEM Linkage using 14mm and 17mm wrench or T-handle.
Remove bearing race from OEM linkage and reinstall into BBR Linkage.

Select inserts for your specific ride height.

Black inserts will be + or – 15 mm ride height
Gray inserts will be + or – 10 mm ride height
Silver inserts with no marking are stock ride height

The offset of the hole will determine if your ride height will be increased or decreased
Positioning the hole forward will increase ride height, and rearward will lower ride height

RIDE HEIGHT INCREASED



RIDE HEIGHT DECREASED



Install linkage into frame using OEM hardware.

Install forward bolt through frame and bearing race tighten to 32 foot-pounds

Install selected inserts into the inside pockets of the linkage. Rotate linkage arm up into shock linkage this will hold the inserts in place while installing outside inserts and bolt.

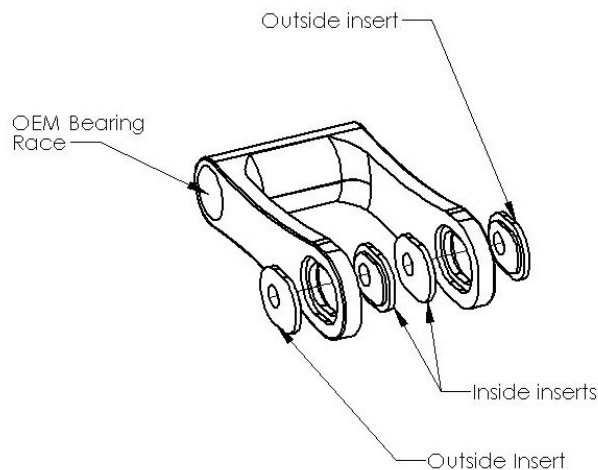

Align insert hole with swingarm linkage. This is easiest accomplished by raising or lowering the swingarm and the BBR linkage until they line up. When holes are aligned install outside insert and bolt through BBR linkage and swigrm linkage. Install other outside insert and nut .

Tighten bolt to 32 foot-pounds.